

Registration form

**Wellfield Operator CEU Training Course \$200.00
48 HOUR RUSH ORDER PROCESSING FEE ADDITIONAL \$50.00**

Start and Finish Dates: _____

You will have 90 days from this date in order to complete this course

Name _____ **Signature** _____

I have read and understood the disclaimer notice on page 2. Digitally sign XXX

Address _____

City _____ **State** _____ **Zip** _____

Email _____ **Fax (_____)** _____

Phone:
Home (_____) _____ **Work (_____)** _____

Operator ID # _____ **Exp. Date** _____

Class/Grade _____

Your certificate will be mailed to you in about two weeks.

Please circle/check which certification you are applying the course CEU's/PDH's.

Water Treatment _____ Distribution _____ Groundwater _____

Well Drillers _____ Pump Installer _____ Other _____

Technical Learning College Western Campus
PO Box 420, Payson AZ 85547-0420
(928) 468-0665 Fax (928) 272-0747 Toll Free (866) 557-1746
info@tlch2o.com

Discover card _____ **CCV code on card** _____

American Express

Visa or MasterCard # _____ **Exp. Date** _____

If you've paid on the Internet, write your Customer # _____

Invoice me, PO # _____

We will stop mailing the certificate of completion so we need your e-mail address. We will e-mail the certificate to you, if no e-mail address; we will mail it to you.

DISCLAIMER NOTICE

I understand that it is my responsibility to ensure that this CEU course is either approved or accepted in my State for CEU credit. I understand State laws and rules change on a frequent basis and I believe this course is currently accepted in my State for CEU or contact hour credit, if it is not, I will not hold Technical Learning College responsible. I also understand that this type of study program deals with dangerous conditions and that I will not hold Technical Learning College, Technical Learning Consultants, Inc. (TLC) liable for any errors or omissions or advice contained in this CEU education training course or for any violation or injury caused by this CEU education training course material. I will call or contact TLC if I need help or assistance and double-check to ensure my registration page and assignment has been received and graded.

State Approval Listing Link, check to see if your State accepts or has pre-approved this course. Not all States are listed. Not all courses are listed. If the course is not accepted for CEU credit, we will give you the course free if you ask your State to accept it for credit.

Professional Engineers; Most states will accept our courses for credit but we do not officially list the States or Agencies. Please check your State for approval or acceptance.

State Approval Listing URL...

<http://www.tlch2o.com/PDF/CEU%20State%20Approvals.pdf>

You can obtain a printed version of the course manual from TLC for an additional \$79.95 plus shipping charges.

AFFIDAVIT OF EXAM COMPLETION

I affirm that I personally completed the entire text of the course. I also affirm that I completed the exam without assistance from any outside source. I understand that it is my responsibility to file or maintain my certificate of completion as required by the state or by the designation organization.

Grading Information

In order to maintain the integrity of our courses we do not distribute test scores, percentages or questions missed. Our exams are based upon pass/fail criteria with the benchmark for successful completion set at 70%. Once you pass the exam, your record will reflect a successful completion and a certificate will be issued to you.

For security purposes, please fax or e-mail a copy of your driver's license and always call us to confirm we've received your assignment and to confirm your identity.

Thank you...

Wellfield Assignment Answer Key

NAME: _____

E-MAIL _____ PHONE _____

Please X, Bold, Circle or X the best answer. One answer per question.

- | | | |
|---------------|---------------|----------------|
| 1. A B C D E | 39. A B C D E | 77. A B C D E |
| 2. A B C D E | 40. A B C D E | 78. A B C D E |
| 3. A B C D E | 41. A B C D E | 79. A B C D E |
| 4. A B C D E | 42. A B C D E | 80. A B C D E |
| 5. A B C D E | 43. A B C D E | 81. A B C D E |
| 6. A B C D E | 44. A B C D E | 82. A B C D E |
| 7. A B C D E | 45. A B C D E | 83. A B C D E |
| 8. A B C D E | 46. A B C D E | 84. A B C D E |
| 9. A B C D E | 47. A B C D E | 85. A B C D E |
| 10. A B C D E | 48. A B C D E | 86. A B C D E |
| 11. A B C D E | 49. A B C D E | 87. A B C D E |
| 12. A B C D E | 50. A B C D E | 88. A B C D E |
| 13. A B C D E | 51. A B C D E | 89. A B C D E |
| 14. A B C D E | 52. A B C D E | 90. A B C D E |
| 15. A B C D E | 53. A B C D E | 91. A B C D E |
| 16. A B C D E | 54. A B C D E | 92. A B C D E |
| 17. A B C D E | 55. A B C D E | 93. A B C D E |
| 18. A B C D E | 56. A B C D E | 94. A B C D E |
| 19. A B C D E | 57. A B C D E | 95. A B C D E |
| 20. A B C D E | 58. A B C D E | 96. A B C D E |
| 21. A B C D E | 59. A B C D E | 97. A B C D E |
| 22. A B C D E | 60. A B C D E | 98. A B C D E |
| 23. A B C D E | 61. A B C D E | 99. A B C D E |
| 24. A B C D E | 62. A B C D E | 100. A B C D E |
| 25. A B C D E | 63. A B C D E | 101. A B C D E |
| 26. A B C D E | 64. A B C D E | 102. A B C D E |
| 27. A B C D E | 65. A B C D E | 103. A B C D E |
| 28. A B C D E | 66. A B C D E | 104. A B C D E |
| 29. A B C D E | 67. A B C D E | 105. A B C D E |
| 30. A B C D E | 68. A B C D E | 106. A B C D E |
| 31. A B C D E | 69. A B C D E | 107. A B C D E |
| 32. A B C D E | 70. A B C D E | 108. A B C D E |
| 33. A B C D E | 71. A B C D E | 109. A B C D E |
| 34. A B C D E | 72. A B C D E | 110. A B C D E |
| 35. A B C D E | 73. A B C D E | 111. A B C D E |
| 36. A B C D E | 74. A B C D E | 112. A B C D E |
| 37. A B C D E | 75. A B C D E | 113. A B C D E |
| 38. A B C D E | 76. A B C D E | 114. A B C D E |

- | | | |
|----------------|----------------|----------------|
| 115. A B C D E | 144. A B C D E | 173. A B C D E |
| 116. A B C D E | 145. A B C D E | 174. A B C D E |
| 117. A B C D E | 146. A B C D E | 175. A B C D E |
| 118. A B C D E | 147. A B C D E | 176. A B C D E |
| 119. A B C D E | 148. A B C D E | 177. A B C D E |
| 120. A B C D E | 149. A B C D E | 178. A B C D E |
| 121. A B C D E | 150. A B C D E | 179. A B C D E |
| 122. A B C D E | 151. A B C D E | 180. A B C D E |
| 123. A B C D E | 152. A B C D E | 181. A B C D E |
| 124. A B C D E | 153. A B C D E | 182. A B C D E |
| 125. A B C D E | 154. A B C D E | 183. A B C D E |
| 126. A B C D E | 155. A B C D E | 184. A B C D E |
| 127. A B C D E | 156. A B C D E | 185. A B C D E |
| 128. A B C D E | 157. A B C D E | 186. A B C D E |
| 129. A B C D E | 158. A B C D E | 187. A B C D E |
| 130. A B C D E | 159. A B C D E | 188. A B C D E |
| 131. A B C D E | 160. A B C D E | 189. A B C D E |
| 132. A B C D E | 161. A B C D E | 190. A B C D E |
| 133. A B C D E | 162. A B C D E | 191. A B C D E |
| 134. A B C D E | 163. A B C D E | 192. A B C D E |
| 135. A B C D E | 164. A B C D E | 193. A B C D E |
| 136. A B C D E | 165. A B C D E | 194. A B C D E |
| 137. A B C D E | 166. A B C D E | 195. A B C D E |
| 138. A B C D E | 167. A B C D E | 196. A B C D E |
| 139. A B C D E | 168. A B C D E | 197. A B C D E |
| 140. A B C D E | 169. A B C D E | 198. A B C D E |
| 141. A B C D E | 170. A B C D E | 199. A B C D E |
| 142. A B C D E | 171. A B C D E | 200. A B C D E |
| 143. A B C D E | 172. A B C D E | |

Please fax or e-mail the answer key to TLC
Western Campus Fax (928) 272-0747.

Rush Grading Service

If you need this assignment graded and the results mailed to you within a 48-hour period, prepare to pay an additional rush service handling fee of \$50.00. This fee may not cover postage costs. If you need this service, simply write RUSH on the top of your Registration Form. We will place you in the front of the grading and processing line.

For security purposes, please fax or e-mail a copy of your driver's license and always call us to confirm we've received your assignment and to confirm your identity. Thank you...

**Wellfield Operator CEU Training Course
CUSTOMER SERVICE RESPONSE CARD**

NAME: _____

E-MAIL _____ PHONE _____

PLEASE COMPLETE THIS FORM BY CIRCLING THE NUMBER OF THE APPROPRIATE ANSWER IN THE AREA BELOW.

1. Please rate the difficulty of your course.

Very Easy 0 1 2 3 4 5 Very Difficult

2. Please rate the difficulty of the testing process.

Very Easy 0 1 2 3 4 5 Very Difficult

3. Please rate the subject matter on the exam to your actual field or work.

Very Similar 0 1 2 3 4 5 Very Different

4. How did you hear about this Course? _____

How about the price of the course?

Poor _____ Fair _____ Average _____ Good _____ Great _____

How was your customer service?

Poor _____ Fair _____ Average _____ Good _____ Great _____

Any other concerns or comments.

Wellfield Operator CEU Training Course Assignment

Please select only one answer per question. There are no intentional trick questions

1. Unconfined aquifers are not sandwiched between layers of relatively impermeable materials, and their upper boundaries are generally?
 - A. Near Cracks or Fractures
 - B. Have more Permeability
 - C. Further from the surface of the land
 - D. Closer to the surface of the land
 - E. None of the Above

2. The term "**aquifer**" literally means?
 - A. Porosity
 - B. Permeability
 - C. Confined and Unconfined
 - D. Water bearer
 - E. Underground Lakes and Rivers

3. Basically, there are two kinds of aquifers:
 - A. Water bearer & Aquifer
 - B. Porosity & Permeability
 - C. Confined and Unconfined
 - D. Underground Lakes and Rivers
 - E. None of the Above

4. Confined aquifers are frequently found at greater depths than unconfined aquifers. In contrast, unconfined aquifers are not sandwiched between these layers of relatively impermeable materials, and their upper boundaries are generally?
 - A. Based in part on the size of these spaces and the extent to which they are connected.
 - B. Closer to the surface of the land
 - C. Relative to the amount of open space present to hold water. Its ability to transmit water.
 - D. None of the Above

5. If the aquifer is sandwiched between layers of relatively impermeable materials (e.g., clay), it is called?
 - A. Water bearer & Aquifer
 - B. Porosity & Permeability
 - C. Confined
 - D. Unconfined
 - E. None of the Above

6. Which type of aquifer is frequently found at greater depths?
 - A. Confined
 - B. Unconfined
 - C. Does not matter
 - D. None of the Above

7. The level below which all the spaces are filled with water is called the?
 - A. Water table
 - B. Unsaturated zone
 - C. Soil moisture
 - D. Saturated zone
 - E. None of Above

8. Above the water table lies the ?
- A. Unsaturated zone
 - B. Water table
 - C. Soil moisture
 - D. Saturated zone
 - E. Groundwater
9. The spaces in the rock and soil contain both air and water. Water in this zone is called ?
- A. Unsaturated zone
 - B. Water table
 - C. Soil moisture
 - D. Saturated zone
 - E. None of Above
10. The entire region below the water table is called the saturated zone, and water in this saturated zone is called?
- A. Unsaturated zone
 - B. Soil moisture
 - C. Saturated zone
 - D. Groundwater
 - E. Water table
11. Groundwater usually flows downhill with the slope of the ?
- A. Unsaturated zone
 - B. Soil moisture
 - C. Saturated zone
 - D. Groundwater
 - E. None of Above
12. Groundwater may move in _____directions below the ground than the water flowing on the surface.
- A. The same
 - B. Different
 - C. Depends
 - D. Upwards
 - E. None of Above
13. The movement of water from an aquifer into a well results in the formation of ?
- A. Unsaturated zone
 - B. Soil moisture
 - C. Saturated zone
 - D. A cone of depression
 - E. None of the Above
14. _____is the vertical drop in the height between the water level in the well prior to pumping and the water level in the well during pumping.
- A. Backflow
 - B. Piezometric surface
 - C. Drawdown
 - D. A cone of depression
 - E. None of Above

15. _____ are those that are bounded by the water table. Some aquifers, however, lie beneath layers of impermeable materials.
- A. Piezometric surface
 - B. Foot
 - C. Drawdown
 - D. A cone of depression
 - E. None of Above
16. The pressure within the aquifer results in a water level rising above the aquifer to the?
- A. Piezometric surface
 - B. Foot
 - C. Drawdown
 - D. A cone of depression
 - E. Unconfined aquifers
17. Sometimes confined aquifers may be _____. These are confined aquifers that have pressures high enough to raise water levels above the upper extent of the aquifer.
- A. Artesian aquifers
 - B. Piezometric surface
 - C. Artesian well
 - D. A cone of depression
 - E. None of Above
18. Occasionally, groundwater may flow naturally from a well constructed in these type of aquifers resulting in a ?
- A. Artesian aquifers
 - B. Piezometric surface
 - C. Artesian well
 - D. A cone of depression
 - E. None of Above
19. _____ are rocks in which the groundwater moves through cracks, joints or fractures in otherwise solid rock.
- A. Basalt
 - B. Fractured aquifers
 - C. Limestones
 - D. Dissolution
 - E. None of Above
20. Examples of aquifers formed by the _____ of solid rock include granite and basalt aquifers.
- A. Basalt
 - B. Fractured aquifers
 - C. Limestones
 - D. Dissolution
 - E. None of Above
21. Limestones are often fractured aquifers, but here the cracks and fractures may be enlarged by _____, forming large channels or even caverns.
- A. Basalt
 - B. Fractured aquifers
 - C. Limestones
 - D. Dissolution
 - E. None of Above

22. Limestone terrain where solution has been very active is termed?
- A. Karst
 - B. Fractured aquifers
 - C. Limestones
 - D. Dissolution
 - E. None of Above
23. Porous media such as sandstone may become so highly cemented or re-crystallized that all of the original space is filled. In this case, the rock is no longer a porous medium. However, if it contains cracks it can still act as a ?
- A. Karst
 - B. Fractured aquifers
 - C. Limestones
 - D. Dissolution
 - E. None of Above
24. Most of the aquifers of importance to us are _____porous media such as sand and gravel. Some very porous materials are not permeable. Clay, for instance, has many spaces between its grains, but the spaces are not large enough to permit free movement of water.
- A. Karst
 - B. Fractured aquifers
 - C. Limestones
 - D. Dissolution
 - E. None of the Above
25. Drilling fluids are often used during drilling in order to keep the _____ open while drilling is done. Drilling fluids stabilize the hole and aid in the removal of cuttings. Typical drilling fluids may be water, mud, air, chemical or natural additives, or combinations of each.
- A. Shaft
 - B. Borehole
 - C. Excavation
 - D. Trench
 - E. None of the Above
26. Air rotary with down hole hammer is particularly suited for _____ drilling.
- A. Sediment
 - B. Hard Rock
 - C. Type C Soil
 - D. Alluvial
 - E. All of the above
27. Mud rotary is better suited for drilling in _____. No matter what type of rig or method is being used a highly trained and skilled driller is required to operate them successfully.
- A. Sediment
 - B. Hard Rock
 - C. Type C Soil
 - D. Alluvial
 - E. All of the above

28. _____ utilizes a drilling rig with a rotating bit and circulating drilling fluid to penetrate into the aquifer. It is the most common type of drilling method used today. Common variations of this method include direct and reverse mud rotary, direct air rotary, and drill through casing driver methods.
- Direct rotary
 - Rotary drilling
 - Kelly
 - Drag
 - None of Above
29. _____ uses a drill string that typically consists of a bit, collar, drill pipe and a kelly (if table driven).
- Direct rotary
 - Rotary drilling
 - Kelly
 - Drag
 - None of Above
30. A _____ is a section of heavy walled pipe that can be hexagonal, square, or rounded with grooves.
- Direct rotary
 - Rotary drilling
 - Kelly
 - Drag
 - None of Above
31. The _____ turns the kelly and the rest of the drill string connected below as it slips down through the table.
- Sub
 - Drive unit
 - Top drive
 - Table drive
 - None of Above
32. Some rotary rigs use a _____ to turn the drill string and is much like a drill press, but much larger.
- Sub
 - Drive unit
 - Top drive
 - Table drive
 - Mast
33. A top drive is free to move up and down the _____ of the rig while rotating the drill string.
- Tri-cone bit
 - Drive unit
 - Top drive
 - Table drive
 - None of Above
34. Drill pipe can be used in various lengths but are typically 20-foot sections and may be connected to the drive unit with a _____.
- Tri-cone bit
 - Drive unit
 - Top drive
 - None of the Above

35. Roller bits, such as the common _____, typically utilize interlocking teeth or buttons on individual rotating cones to cut, crush, or chip through the formation.
- A. Tri-cone bit
 - B. Drive unit
 - C. Top drive
 - D. Table drive
 - E. Mast
36. _____ are also aided by the jetting of drilling fluids from nozzles or jets in the bit.
- A. Roller bits
 - B. Under reaming
 - C. Reamers
 - D. Carbide buttons
 - E. None of Above
37. These bits can be used in consolidated formations and even hard rock applications if equipped with _____.
- A. Roller bits
 - B. Under reaming
 - C. Reamers
 - D. Carbide buttons
 - E. None of Above
38. _____ are bits that can be used to enlarge, straighten, or clean an existing borehole.
- A. Roller bits
 - B. Under reaming
 - C. Reamers
 - D. Carbide buttons
 - E. None of the Above
39. _____ involves the projection of cutting blades beneath permanently installed casing in loosely consolidated sediments. This can allow for the cost effective installation of well screen and gravel pack within deeper loosely consolidated aquifers.
- A. Roller bits
 - B. Under reaming
 - C. Reamers
 - D. Carbide buttons
 - E. None of Above

Identify the following pictures

40.

- A. Reamer
- B. Tricone Roller Bits
- C. Roller Reamer
- D. Drag Bit
- E. Percussion Bits



41.

- A. Reamer
- B. Tricone Roller Bits
- C. Roller Reamer
- D. Drag Bit
- E. Percussion Bits

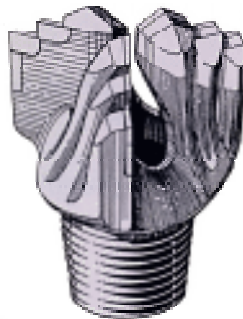

42.

- A. Reamer
- B. Tricone Roller Bits
- C. Roller Reamer
- D. Drag Bit
- E. Sand Bailer



43.
A. Reamer
B. Tricone Roller Bits
C. Roller Reamer
D. Drag Bit
E. Cutting Shoe



44.
A. Reamer
B. Tricone Roller Bits
C. Roller Reamer
D. Drag Bit
E. Percussion Bits



45. Direct rotary drilling methods utilize a rotating bit at the end of a drilling string with drilling fluid that is circulated from the rig through the drill pipe and jets in the bit.
A. True
B. False
46. The drilling fluid that is pumped by the rigs mud pump and/or air compressor is jetted out of ports in the bit. These ports are called **kellys**.
A. True
B. False
47. The drilling fluid carries cuttings up the annular space between the drill pipe and formation and into mud pits or containment recirculating systems on the surface. The drilling fluid cools the borehole and helps to keep the water clean while removing cuttings.
A. True
B. False
48. Large drill rigs may utilize cuttings containment systems that separate the cuttings from the drilling fluid before a pickup pump recirculates the drilling fluid back down the borehole, were the process is then done in the reverse order. Also, one or more temporary mud pits may be dug into the ground adjacent to the rig in order to contain and settle out cuttings from the drilling fluid before recirculating.
A. True
B. False
49. Direct transient rotary drilling rigs use various types of mud or drilling fluid to drill into the ground. Mud is circulated down the drill string and through the bit at the top of the borehole.
A. True
B. False

50. The process of building up a film of mud on the borehole walls is important to mud rotary drilling and is called mud caking. Sometimes specially trained personnel are needed to manage the physical properties of the mud to ensure that a proper mud cake thickness is maintained and that a proper density or weight of mud is used to efficiently drill the well.

- A. True
- B. False

51. The mud engineer will often use bentonite clay and soap to make the mud drilling fluid. Sometimes chemical additives such as oxidizers and caustics may be used. Mud engineers play an important role in ensuring that a mud rotary drilled well can be drilled to the proper depths successfully and ultimately developed for use.

- A. True
- B. False

52. Sometimes the loss of mud drilling fluids to cavities in the earth cannot be stopped with a mud cake alone however. In these instances, casing or grout may be installed to permit drilling beyond such zones.

- A. True
- B. False

53. Mud rotary methods utilize compressed air and derived drill cuttings and groundwater as the drilling fluid. Mud is forced through the drill string and out the bit where it then mixes with and lifts cuttings and any derived groundwater to the surface. Once at the surface, the cuttings and groundwater are typically contained in subsurface pits, much like the mud rotary method.

- A. True
- B. False

54. Biodegradable foam or surfactant (**soap**) is often added while drilling with air in order to maintain sufficient hole pressurization so that cuttings may be lifted to the surface efficiently while maintaining hole stability.

- A. True
- B. False

55. The air rotary method is particularly suitable to hard rock drilling with a down hole air hammer. The air hammer utilizes compressed air to drive a piston up and down which makes the hammer bit move up and down while the drill string rotates. The combined rotating and hammering action generates great rock breaking force and is very valuable for drilling through solid rock or consolidated formations.

- A. True
- B. False

56. Conventional air rotary drilling methods utilize roller bits in the same way as those used for mud rotary drilling. In hard rock or consolidated formations a roller button bit may be used when drilling pressures are too high or borehole sizes are too large for the efficient operation of an air hammer.

- A. True
- B. False

57. Auger boring methods make use of a rotating blade or spiral flange that may be attached to a pilot bit and cutter head. Down-force applied by the rig along with the rotating action of the blade and cutting action of the pilot and/or cutter bits facilitates the boring process.

- A. True
- B. False

58. Augers are capable of boring large diameter holes in excess of four feet in diameter. They are typically used in shallow applications (less than 200 feet) and where stable silt and clay soils or soft materials are dominant.

- A. True
- B. False

59. One of the methods is commonly used in environmental applications for the collection soil samples. There are three primary types of auger boring methods: rotary stem, bucket, and butterfly.

- A. True
- B. False

60. The solid stem auger boring method uses a spiral flanged drill pipe driven by either a globe or rotary drive head like those used on dayton rigs. The drill pipe may be continuously flanged or just the initial section is welded.

- A. True
- B. False

61. Welded sections of drill pipe are referred to as *flighting*.

- A. True
- B. False

62. Larger diameter augers typically employ a single flight and can be used in stable formations to depths of approximately 600 feet.

- A. True
- B. False

63. Samples may be collected from these cuttings or the flighting may be brought to the surface and samples collected from the cutting head. This method is not suited for applications below the water table and may provide limited soil sample data. However, it may be used to aid in quickly constructing the larger diameter upper sections for larger wells.

- A. True
- B. False

64. The globe auger method essentially combines the rotary and auger techniques.

- A. True
- B. False

65. The Bucket auger method employs a single, typically large in diameter, bucket auger to drill or bore into the ground. The bucket auger is a cylinder constructed with auger like blades at its bottom edge. These blades may be armored with various forms of cutting teeth or blades to provide strength and "**bite**".

- A. True
- B. False

66. The bucket auger is rotated via a kelly and table drive much like those of rotary rigs.

- A. True
- B. False

67. Bucket auger rigs utilize a telescoping kelly.

- A. True
- B. False

68. This type of kelly allows the rig to drill to depths of 4,000 feet or more without requiring the addition and removal of drill pipe. When the bucket is filled with cuttings it is closed and brought to the surface where it is swung out to the side of the rig by a specially designed swing arm or dumping arm. At this point the bucket is closed and cuttings are dumped. Soil samples may then be collected and can be considered representative of section bored.

- A. True
- B. False

69. Bucket auger methods typically cannot be used in material containing cobbles and boulders, but is used most often in more stable semi consolidated silty or clay rich deposits. Large diameter wells up to 4 feet in diameter may be constructed with the bucket auger method with smaller diameters approaching 200 feet in depth. Occasionally drilling fluids such as bentonite mud, may be used in order to maintain borehole stability when drilling in questionable materials.

- A. True
- B. False

70. The cable tool or percussion method is one of the oldest and most reliable forms of well drilling still used today. This method is adaptable to virtually every kind of drilling environment. As a result, numerous variations in both rig types and methods have evolved over its history. However, it is often used as a method of last resort when time is an issue, due to its typically slow process.

- A. True
- B. False

71. The cable tool method can surely succeed where any of the other methods fail.

- A. True
- B. False

72. Cable tool or percussion drilling methods utilize a system of cranes and cleaves to lift and drop a kelly string as downward progress is made. The weight and force of the kelly impact breaks up the ground and permits a typically slow, but steady, downward movement.

- A. True
- B. False

73. Water is used as the primary drilling fluid. As drilling proceeds, cuttings and water mix forming a slurry. This slurry is allowed to pass back and forth through a water course or opening within the drill string. The drill sting is welded to the shaft to prevent theft.

- A. True
- B. False

74. A bailer is a section of pipe constructed with a pressure relief valve located at the bottom of the pipe. As the bailer is lowered it fills with the drilling fluid and cuttings. When the bailer is raised up, the PRV at the bottom of the pipe closes, trapping the slurry inside. The slurry can then be lifted to the surface and the contents dumped into a containment system where samples may then be collected.

- A. True
- B. False

75. The cable tool drill string is comprised of a cable, swivel socket, drilling jars, drill stem, and drill bit. The primary cable is used to lift and drop the drill string while the swivel socket provides a rotating mechanism. The rotation allowed by the swivel socket ensures that fresh cuts are made with each strike of the bit. The drilling jars are used only for additional upward shock to remove the bit should it become stuck in the borehole.

- A. True
- B. False

76. The drill stem provides the majority of the weight of the drill string and also helps to maintain a straight borehole. It serves the same purpose as does the drill collar used in rotary methods. Cable tool bits are normally a round shape, although numerous variations may be used for different formations, including iron and copper coated bits for consolidated formations.

- A. True
- B. False

77. The borehole may remain open or casing may be advanced while drilling, in order to keep the borehole open in unstable formations. Casing is advanced by either pushing it hydraulically, like a large press, or by driving it down with the drill string or a drive block.

- A. True
- B. False

78. The dayton is a heavy collar type device that attaches over the flex coupling and is lifted up and allowed to fall, striking the casing and forcing it down.

- A. True
- B. False

79. Drilling, casing advancement, and bailing alternate as the borehole gets progressively deeper. If the casing becomes too difficult to advance further and the required drill depth has yet to be achieved, a smaller borehole and casing may be used inside of the outer casing in order to continue. This is called "**Walking**".

- A. True
- B. False

80. All wells must be constructed with a mechanical seal to prevent the infiltration of surface water and/or surface contaminants into the well bore and aquifer.

- A. True
- B. False

81. This seal is installed in the below portions of the well bore between the annulus and surface casing and will normally extend to the ground surface around the well.

- A. True
- B. False

82. The seal is constructed by pouring or pumping neat cement grout and/or bentonite between the surface casing and the well bore.

- A. True
- B. False

83. The installation of the cement or grout between the annulus and surface casing effectively seals off the upper borehole from the surface.

- A. True
- B. False

84. The surface casing used is a solid piece of permanently installed casing, usually steel, that should be of sufficient size to allow the completion of the well within it.

- A. True
- B. False

85. When the well was drilled into the aquifer the depths of water productive intervals and estimated well yield are normally logged by the driller or geologist.

- A. True
- B. False

86. Following the installation of the wells surface seal, the well is then reamed (if necessary) to accept additional blank casing, 90 bends, Street L's, and filter or gravel pack.

- A. True
- B. False

87. Once the well has been reamed large enough in diameter for the anticipated flow rate, the wells casing can be installed. The well casing ensures that the borehole remains open and that debris from the formation(s) do not enter the well, thereby protecting the pump equipment and well itself.

- A. True
- B. False

88. Blank casing is normally installed to the depth of the main producing zone. At this point well screen is used and may extend to the total depth of the well or may be used intermittently to total depth with blank casing used through unstable or non-productive areas.

- A. True
- B. False

89. As with casing, the choice of well screen is as important as its placement. The size of the openings in the casing (screen slot or perforated opening size) is dependent on the disinfectant used.

- A. True
- B. False

90. As a rule, coarse grained sediment or fractured aquifers may be naturally developed while fine-grained sediment aquifers typically require a filter pack. The selection of screen slot size is normally made based on samples collected from the aquifer during drilling and consideration of the filter or gravel pack grain-size.

- A. True
- B. False

91. As a rule, wire wrapped screen or continuous screen is normally used in municipal applications where a **low yield** is obtained from **unconsolidated** to **semi-consolidated** formations.

- A. True
- B. False

92. Slotted and perforated screens are stronger and more expensive than wire wrapped screens and are best suited to deep, where borehole stability is a concern, and in domestic applications.

- A. True
- B. False

93. Louvered screen is used in high yield production wells but particularly where cascading water is a problem. The louvers deflect groundwater above pumping levels back into the annulus or filter pack so that air entrainment and corrosion within the well are minimized.

- A. True
- B. False

94. Air entrainment occurs when cascading water rises into the pumping water level creating turbulence that makes bubbles. These bubbles may get drawn into a **vortex** created by the depth of the water.

- A. True
- B. False

95. Once the casing and screen specifications are determined they may be installed into the well. Due to weight, casing is often installed with a drill rig. If a well is telescoped the driller will install the largest diameter portions first. Gravel or filter packs can then be installed.

- A. True
- B. False

96. A bentonite or cement plug is often installed in the bottom of the borehole before the filter pack is installed. If certain intervals of the well need to be isolated from others, inflatable packers with bentonite or cement grout may be used.

- A. True
- B. False

97. The kelly is used to seal off a portion of the annulus to prevent the movement of seal material into the filter pack. These types of seals are commonly used for wells constructed within confined aquifers so that they may remain isolated and avoid cross connection with other aquifers.

- A. True
- B. False

98. Appropriate location of the well reduces the possibility of contamination.

- A. True
- B. False

99. The ideal well location has good drainage and is higher than the surrounding ground surface. All possible sources of contamination should be at a lower elevation than the well, and the distances to those contamination sources must be in accordance with the State or Local Water Well Construction Code. Surface drainage should not allow surface water to accumulate within a 5-foot radius of the well. A well must never be located closer than 2 feet to sewers, 10 feet to septic tanks, or 25 feet to sewage seepage fields.

- A. True
- B. False

100. A well should be higher than the surrounding ground surface for good drainage. All possible sources of contamination should be at a lower elevation than the well, and the distances to those contamination sources must be in accordance with the State or Local Water Well Construction Code.

- A. True
- B. False

101. Surface water should not accumulate within a 15-foot radius of the well. A well must never be located closer than 10 feet to sewers, and 50 feet to septic tanks, or 75 feet to sewage seepage fields.

- A. True
- B. False

102. A bored well with a diameter of 3 feet, a total depth of 50 feet and a water depth of 30 feet, contains approximately 1,600 gallons of water.

- A. True
- B. False

103. Bored wells are usually constructed utilizing the buried slab method. With this method, the upper well casing shall extend to a depth of 10 feet or more below ground surface and be firmly imbedded in a uniformly tapered hole that is formed when the reinforced concrete buried slab is manufactured, or shall be connected to a pipe cast in the concrete slab.

- A. True
- B. False

104. For bored wells not finished with a buried slab, the concrete casing also ranges in diameter from 20 to 30 feet. The annular space between the excavation and the installed casing should be grouted with concrete that is at least 6 inches thick and poured without construction joints from a minimum of 100 feet below ground level to the ground surface.

- A. True
- B. False

105. A new, cleaned or repaired well normally contains contamination that could be present for weeks unless the well is thoroughly disinfected. This can be accomplished by the use of ordinary liquid laundry bleach (unscented) in a solution concentration of 1,000 parts per million (ppm) of chlorine. The amount of bleach required is determined by the amount of water in the well.

- A. True
- B. False

106. Amount of laundry bleach (5.25% chlorine) required for each 100 gallons of water equals 3 cups. One equals 8 ounces, 2 cups equal 1 pint, and 4 cups equal 1 quart.

- A. True
- B. False

107. Water system demand comes from a number of sources including residential, commercial, industrial and public consumers as well as some unavoidable loss and waste. If fire protection is desired, that could also represent a rather significant (although not continuous) demand upon the system.

- A. True
- B. False

108. The combination of storage reservoirs and distribution lines must be capable of meeting consumers' needs for headloss at all times.

- A. True
- B. False

109. The quantity of water used in any community varies from 50 to 500 gallons per person per day. A common design assumption is to use from 100 to 150 gallons per person per day for average domestic use.

- A. True
- B. False

110. The maximum daily use is approximately 6 to 7 times the average daily use. Maximum daily use is usually encountered during the summer months and can vary widely depending on irrigation practices.

- A. True
- B. False

111. When a well is installed in an confined aquifer, water moves from the aquifer into the well through small holes or slits in the well casing or, in some types of wells, through the open top of the well. The level of the water in the well is the same as the water level in the aquifer. Groundwater continues to flow through and around the well in one direction in response to gravity.

- A. True
- B. False

112. When abandoned wells are left open, children, animals or even adults can fall into them, causing injury or death. To prevent such accidents, all abandoned wells must be properly sealed.

- A. True
- B. False

113. If improperly sealed, an abandoned well can serve as a route for contaminating groundwater. Contaminated surface water, agricultural runoff and effluent from private sewage disposal systems can enter the groundwater through such wells and cause pollution of other wells in the area used for drinking water.

- A. True
- B. False

114. Wells should not be located within vaults or pits, except with a ***variance permit***.

- A. True
- B. False

The following questions will be concept-based and may be difficult to find.

Distribution Valves

115. The purpose of installing _____ in water mains at various locations within the distribution system is to allow sections of the system to be taken out of service for repairs or maintenance without significantly curtailing service over large areas.

- A. Distribution system
- B. Branch mains
- C. Shutoff valves
- D. Distribution loops
- E. None of the Above

116. Valves should be installed at intervals not greater than 5,000 feet in long supply lines and 1,500 feet in main _____ or feeders.

- A. Distribution system
- B. Branch mains
- C. Shutoff valves
- D. Distribution loops
- E. None of the Above

117. All _____ connecting to feeder mains or feeder loops should have valves installed as close to the feeders as practical. In this way, branch mains can be taken out of service without interrupting the supply to other locations.

- A. Distribution system
- B. Branch mains
- C. Shutoff valves
- D. Distribution loops
- E. None of the Above

118. In the areas of greatest water demand or when the dependability of the _____ is particularly important, valve spacing of 500 feet maybe appropriate.

- A. Distribution system
- B. Branch mains
- C. Shutoff valves
- D. Distribution loops
- E. None of the Above

119. At intersections of distribution mains, the number of valves required is normally one less than the number of _____.

- A. Distribution system
- B. Radiating mains
- C. Shutoff valves
- D. Distribution loops
- E. None of the Above

120. The _____ omitted from the line is usually the one that principally supplies flow to the intersection.
- A. Distribution system
 - B. Branch mains
 - C. Valve
 - D. Distribution loops
 - E. None of the Above
121. _____ should be installed in standardized locations (that is, the northeast corner of intersections or a certain distance from the center line of streets), so they can be easily found in emergencies.
- A. Distribution system
 - B. Branch mains
 - C. Shutoff valves
 - D. Distribution loops
 - E. None of the Above
122. All buried small- and medium-sized valves should be installed in _____.
- A. Distribution system
 - B. Branch mains
 - C. Valve boxes
 - D. Distribution loops
 - E. None of the Above
123. Large _____ (about 30 inches in diameter and larger), it may be necessary to surround the valve operator or entire valve within a vault or manhole to allow repair or replacement.
- A. Distribution system
 - B. Branch mains
 - C. Shutoff valves
 - D. Distribution loops
 - E. None of the Above
124. There are two major classifications of _____: Rotary and Linear.
- A. Distribution system
 - B. Branch mains
 - C. Water valves
 - D. Distribution loops
 - E. None of the Above
125. _____ are used when a straight-line flow of fluid and minimum flow restriction are needed.
- A. Gate valves
 - B. Thermal binding
 - C. Pressure equalizer
 - D. Over-pressurization
 - E. None of the Above
126. _____ are so-named because the part that either stops or allows flow through the valve acts somewhat like a gate. The gate is usually wedge-shaped.
- A. Gate valves
 - B. Thermal binding
 - C. Pressure equalizer
 - D. Over-pressurization
 - E. None of the Above

127. When the valve is wide open the gate is _____ into the valve bonnet. This leaves an opening for flow through the valve the same size as the pipe in which the valve is installed.

- A. Fully drawn up
- B. Thermal binding
- C. Pressure equalizer
- D. Over-pressurization
- E. None of the Above

128. Gate valves are not suitable for _____. The control of flow is difficult because of the valve's design, and the flow of fluid slapping against a partially open gate can cause extensive damage to the valve.

- A. Gate valves
- B. Throttling purposes
- C. Pressure equalizer
- D. Over-pressurization
- E. None of the Above

129. _____ in the temperature and/or pressure of the working fluid are often the cause of a valve failing to open.

- A. Gate valves
- B. Variations
- C. Pressure equalizer
- D. Over-pressurization
- E. None of the Above

QA/QC Section, the next set of questions are to ensure you are not cheating. These questions may be repeats.

130. _____ can occur in high temperature situations depending on the seat and wedge material, length of exposure and closing torque applied.

- A. Gate valves
- B. Thermal binding
- C. Pressure equalizer
- D. Over-pressurization
- E. None of the Above

131. _____ can cause galling on the valve sealing surfaces as well as on the guides.

- A. Gate valves
- B. Thermal binding
- C. Pressure equalizer
- D. Over-pressurization
- E. None of the Above

132. A valve can lock in the closed position when high pressure enters the cavity and has no way to escape. This is known as _____.

- A. Gate valves
- B. Thermal binding
- C. Pressure equalizer
- D. Over-pressurization
- E. None of the Above

133. _____ in the temperature and/or pressure of the working fluid are often the cause of a valve failing to open.

- A. Thermal binding
- B. Pressure equalizer
- C. Variations
- D. None of the Above

134. _____ can occur in high temperature situations depending on the seat and wedge material, length of exposure and closing torque applied.

- A. Gate valves
- B. Thermal binding
- C. Pressure equalizer
- D. Over-pressurization
- E. None of the Above

135. _____ can cause galling on the valve sealing surfaces as well as on the guides.

- A. Gate valves
- B. Thermal binding
- C. Pressure equalizer
- D. Over-pressurization
- E. None of the Above

136. A valve can lock in the closed position when high pressure enters the cavity and has no way to escape. This is known as _____.

- A. Single direction sealing
- B. Thermal binding
- C. Pressure equalizer
- D. Over-pressurization
- E. None of the Above

137. _____ gate valves have a nameplate on the side of the valve that has a relief hole or pressure equalizer. This should be the high pressure side when the valve is closed.

- A. Single direction sealing
- B. Thermal binding
- C. Pressure equalizer
- D. Over-pressurization
- E. None of the Above

138. Most Globe valves have compact _____ type, bolted bonnet, rising stem, with renewable seating valves.

- A. Globe valves
- B. Bonnet
- C. Seat
- D. Throttling
- E. None of the Above

139. A Check Valve spring loaded disc resulting with most advanced design features provides the _____ in dependable, economical flow control.

- A. Globe valves
- B. Bonnet
- C. Seat
- D. Throttling
- E. None of the Above

140. _____ should usually be installed with the inlet below the valve seat.

- A. Globe valves
- B. Bonnet
- C. Seat
- D. Throttling
- E. None of the Above

141. For severe throttling service, the valve may be installed so that the flow enters over the top of the _____ and goes down through it. Note that in this arrangement, the packings will be constantly pressurized.

- A. Globe valves
- B. Bonnet
- C. Seat
- D. Throttling
- E. None of the Above

142. If the valve is to be installed near _____ service, verify with an outside contractor or a skilled valve technician.

- A. Globe valves
- B. Bonnet
- C. Seat
- D. Throttling
- E. None of the Above

143. The valve should be welded onto the line with the disc in the fully _____. Leaving it even partially open can cause distortion and leaking. Allow time for the weld to cool before operating the valve the first time in the pipeline.

- A. Globe valves
- B. Bonnet
- C. Seat
- D. Throttling
- E. None of the Above

144. The preferred orientation of a _____ is upright. The valve may be installed in other orientations, but any deviation from vertical is a compromise.

- A. Globe valve
- B. Bonnet
- C. Seat
- D. Throttling
- E. None of the Above

145. Installation upside down is not recommended because it can cause dirt to accumulate in the _____.

- A. Globe valves
- B. Bonnet
- C. Seat
- D. Throttling
- E. None of the Above

146. _____ is trapped on threads and/or in the packing area: This is a common problem when valves are installed outdoors in sandy areas and area not cleaned before operating.

- A. Valve components
- B. Quick-acting
- C. Foreign debris
- D. None of the Above

147. Always inspect threads and packing area for particle obstructions, even seemingly small amounts of sand trapped on the drive can completely stop large valves from _____.

- A. Valve components
- B. Quick-acting
- C. Foreign debris
- D. None of the Above

148. The valve may stop abruptly when a cycle is attempted. With the line pressure removed from the valve, disconnect the actuator, gear operator or _____ and inspect the drive nut, stem, bearings and yoke bushing.

- A. Valve components
- B. Quick-acting
- C. Foreign debris
- D. None of the Above

149. Contaminated parts should be cleaned with a lint-free cloth using alcohol, varsol or equivalent. All parts should be re-lubricated before re-assemble. If the valves are installed outdoors in a sandy area, it may be desirable to cover the _____ with jackets.

- A. Valves
- B. Quick-acting
- C. Foreign debris
- D. Handwheel
- E. None of the Above

150. If the _____ are faulty or damaged: If you suspect that the valve components are damaged or faulty contact specialized services or an outside contractor.

- A. Valve components
- B. Quick-acting
- C. Foreign debris
- D. Handwheel
- E. None of the Above

151. If the valves _____ is too small: Increasing the size of the handwheel will reduce the amount of torque required to operate the valve. If a larger handwheel is installed, the person operating the valve must be careful not to over-torque the valve when closing it.

- A. Valve components
- B. Quick-acting
- C. Foreign debris
- D. Handwheel
- E. None of the Above

152. Most ball valves are the _____ type. They require only a 90-degree turn to either completely open or close the valve.

- A. Valve components
- B. Quick-acting
- C. Foreign debris
- D. Handwheel
- E. None of the Above

153. Many ball valves are operated by _____. This type of gearing allows the use of a relatively small handwheel and operating force to operate a fairly large valve. Always follow standard safety procedures when working on a valve.

- A. Valve components
- B. Quick-acting
- C. Foreign debris
- D. Planetary gears
- E. None of the Above

154. Butterfly Valves are usually found in both treatment plants and throughout the distribution system. If the valve is not broken, it is relatively easy to operate. It is usually accompanied by a Gate valve used as a by-pass to prevent _____.

- A. Bypass
- B. Water Hammer
- C. Valve
- D. Disc
- E. None of the Above

155. These are _____ types of valves usually found on large transmission lines. They may also have an additional valve beside it known as a "bypass" to prevent a water hammer.

- A. Bypass
- B. Rotary
- C. Valve
- D. Disc
- E. None of the Above

156. Some of these _____ valves can require 300-600 turns to open or close.

- A. Bypass
- B. Butterfly
- C. Valve
- D. Disc
- E. None of the Above

157. Most Valvemmen or the politically correct term Valve Operators will use a machine to open or close a _____ Valve, the machine will count the turns required to open or close the valve.

- A. Bypass
- B. Butterfly
- C. Valve
- D. Disc
- E. None of the Above

158. _____ valves should be installed with the valve shaft horizontal or inclined from vertical. Always follow standard safety procedures when working on a valve.

- A. Bypass
- B. Butterfly
- C. Valve
- D. Disc
- E. None of the Above

159. The valve should be mounted in the _____, with the "HP" marking. Thermal insulation of the valve body is recommended for operating temperatures above 392°F (200°C).

- A. Bypass
- B. Butterfly
- C. Valve
- D. Disc
- E. None of the Above

160. The Butterfly Valve should be installed in the closed position to ensure that the laminated seal in the _____ is not damaged during installation.

- A. Bypass
- B. Butterfly
- C. Valve
- D. Disc
- E. None of the Above

161. If the pipe is lined, make sure that the valve _____ does not contact the pipe lining during the opening stroke. Contact with lining can damage the valve disc.

- A. Bypass
- B. Butterfly
- C. Valve
- D. Disc
- E. None of the Above

Butterfly Valve Problems

A butterfly valve may have jerky operation for the following reasons:

162. If the packing is too tight: _____ the packing torque until it is only hand tight. Tighten to the required level and then cycle the valve. Re-tighten, if required. CAUTION: Always follow safety instructions when operating on valve.

- A. Re-tighten
- B. Clean or replace
- C. Increase
- D. Remove
- E. None of the Above

163. If the shaft seals are dirty or worn out: _____ components, as per assembly-disassembly procedure. CAUTION: Always follow safety instructions when operating on valve.

- A. Re-tighten
- B. Clean or replace
- C. Increase
- D. Remove
- E. None of the Above

164. If the shaft is _____: The shaft must be replaced. Remove valve from service and contact an outside contractor or your expert fix it person.

- A. Re-tighten
- B. Clean or replace
- C. Increase
- D. Remove
- E. None of the Above

165. If the actuator/shaft adaptor is _____: Remove the actuator mounting and realign.

- A. Re-tighten
- B. Clean or replace
- C. Increase
- D. Remove
- E. None of the Above

166. If the valve has a pneumatic actuator, the air supply may be inadequate: Increase the air supply pressure to standard operating level. Any combination of the following may prevent the valve shaft from _____.

- A. Re-tighten
- B. Clean or replace
- C. Increase
- D. Remove
- E. None of the Above

167. If the actuator is not working: _____ or repair the actuator as required. Please contact specialized services or an outside contractor for assistance.

- A. Re-tighten
- B. Replace
- C. Increase
- D. Remove
- E. None of the Above

168. If the valve is packed with debris: _____ the valve and then flush to remove debris. A full cleaning may be required if flushing the valve does not improve valve shaft rotation. Flush or clean valve to remove the debris.

- A. Re-tighten
- B. Clean or replace
- C. Increase
- D. Remove
- E. None of the Above

Backflow Prevention and Cross-Connection Principles Atmospheric Pressure

169. The _____ is the entire mass of air that surrounds the earth.

- A. Troposphere
- B. Atmosphere
- C. Mercury column barometer
- D. Pressures
- E. None of the Above

170. It extends upward for about 500 miles, the section of primary interest is the portion that rests on the earth's surface and extends upward for about 7 1/2 miles. This layer is called the _____.

- A. Troposphere
- B. Atmosphere
- C. Mercury column barometer
- D. Pressures
- E. None of the Above

171. If a column of air 1-inch square extending all the way to the "**top**" of the _____ could be weighed, this column of air would weigh approximately 14.7 pounds at sea level.

- A. Troposphere
- B. Atmosphere
- C. Mercury column barometer
- D. Pressures
- E. None of the Above

172. _____ at sea level is approximately 14.7 psi.

- A. Troposphere
- B. Atmospheric pressure
- C. Mercury column barometer
- D. Pressures
- E. None of the Above

173. As one ascends, the _____ decreases by approximately 1.0 psi for every 2,343 feet.
- A. Troposphere
 - B. Atmospheric pressure
 - C. Mercury column barometer
 - D. Pressures
 - E. None of the Above
174. Below sea level, in excavations and depressions, _____ increases.
- A. Troposphere
 - B. Atmospheric pressure
 - C. Mercury column barometer
 - D. None of the Above
175. _____ under water differ from those under air only because the weight of the water must be added to the pressure of the air.
- A. Troposphere
 - B. Atmospheric pressure
 - C. Mercury column barometer
 - D. Pressures
 - E. None of the Above
176. Atmospheric pressure can be measured by any of several methods. The common laboratory method uses the _____.
- A. Troposphere
 - B. Atmospheric pressure
 - C. Mercury column barometer
 - D. Pressure of the air
 - E. None of the Above
177. The height of the _____ serves as an indicator of atmospheric pressure.
- A. Troposphere
 - B. Atmospheric pressure
 - C. Mercury column
 - D. Pressure of the air
 - E. None of the Above
178. At sea level and at a temperature of 0° Celsius (**C**), the height of the _____ is approximately 30 inches, or 76 centimeters. This represents a pressure of approximately 14.7 psi. The 30-inch column is used as a reference standard.
- A. Sea level
 - B. Atmospheric pressure
 - C. Mercury column
 - D. Aneroid barometer
 - E. None of the Above
179. Another device used to measure atmospheric pressure is the _____.
- A. Sea level
 - B. Atmospheric pressure
 - C. Mercury column barometer
 - D. Aneroid barometer
 - E. None of the Above

180. The _____ uses the change in shape of an evacuated metal cell to measure variations in atmospheric pressure.

- A. Sea level
- B. Atmospheric pressure
- C. Mercury column barometer
- D. Aneroid barometer
- E. None of the Above

181. The _____ does not vary uniformly with altitude.

- A. Sea level
- B. Atmospheric pressure
- C. Mercury column barometer
- D. Aneroid barometer
- E. None of the Above

182. _____ changes are more rapid. Atmospheric pressure is defined as the force per unit area exerted against a surface by the weight of the air above that surface.

- A. Sea level
- B. Atmospheric pressure
- C. Mercury column barometer
- D. Aneroid barometer
- E. None of the Above

183. _____ may be referred to using an absolute scale, pounds per square inch absolute (psia), or gauge scale, (psiag).

- A. Absolute
- B. Pressure
- C. Gauge
- D. Vacuum
- E. None of the Above

184. Absolute pressure and gauge pressure are related. Absolute pressure is equal to _____ pressure plus the atmospheric pressure. At sea level, the atmospheric pressure is 14.7 psai.

- A. Absolute
- B. Pressure
- C. Gauge
- D. Vacuum
- E. None of the Above

185. Absolute pressure is the _____.

- A. Absolute
- B. Pressure
- C. Gauge
- D. Vacuum
- E. None of the Above

186. _____ pressure is simply the pressure read on the gauge. If there is no pressure on the gauge other than atmospheric, the gauge will read zero. Then the absolute pressure would be equal to 14.7 psi, which is the atmospheric pressure.

- A. Absolute
- B. Pressure
- C. Gauge
- D. Vacuum
- E. None of the Above

187. The term vacuum indicates that the absolute pressure is less than the atmospheric pressure and that the _____ pressure is negative.

- A. Absolute
- B. Pressure
- C. Gauge
- D. Vacuum

188. A complete or total _____ would mean a pressure of 0 psia or -14.7 psig.

- A. Absolute
- B. Pressure
- C. Gauge
- D. Vacuum
- E. None of the Above

189. Since it is impossible to produce a total vacuum, the term vacuum, will mean all degrees of _____ vacuum.

- A. Absolute
- B. Pressure
- C. Gauge
- D. Vacuum
- E. None of the Above

190. Which of the following problems may occur during periods of high flow or a fire when the waterline's pressure has dropped drastically?

- A. Negative pressure in parts of the system
- B. Water hammer
- C. Low velocity throughout the system
- D. All of the above
- E. None of the Above

191. This type of valve which controls water pressure operates by restricting flows. They are used to deliver water from a high pressure to a low pressure system. The pressure downstream from the valve regulates the amount of flow. Usually, these valves are of the globe design and have a spring-loaded diaphragm that sets the size of the opening.

- A. Pressure Regulation Valve
- B. A Butterfly Valve
- C. Reduced Pressure
- D. Bypass Valve
- E. Check Valve

192. What is the intent of a designer when multiple water pumps are installed for paralleled operation?

- A. To increase the discharge head
- B. To provide for a fluctuating demand/or for if one pump is out of service
- C. To increase the water force
- D. To help build the kingdom/spend the budget

193. Legionella: No MCL limit, but EPA believes that if **Giardia** and viruses are inactivated, Legionella will also be controlled.

- A. True
- B. False

194. Turbidity: At no time can turbidity (cloudiness of water) go above 5 nephelometric turbidity units (**NTU**); systems that filter must ensure that the turbidity go no higher than 1 NTU (0.5 NTU for conventional or direct filtration) in at least 95% of the daily samples in any month.

- A. True
- B. False

Identify the Pump components

195.

- A. Bearing Housing
- B. Shaft Sleeve
- C. Packing
- D. Thrust Bearing
- E. Line Bearings

196.

- A. Bearing Housing
- B. Shaft Sleeve
- C. Packing
- D. Thrust Bearing
- E. Line Bearings

197.

- A. Bearing Housing
- B. Shaft Sleeve
- C. Packing
- D. Thrust Bearing
- E. Line Bearings

198.

- A. Bearing Housing
- B. Shaft Sleeve
- C. Packing
- D. Thrust Bearing
- E. Line Bearings

199.

- A. Bearing Housing
- B. Shaft Sleeve
- C. Packing
- D. Impeller
- E. Line Bearings

200.

- A. Bearing Housing
- B. Shaft Sleeve
- C. Packing
- D. Thrust Bearing
- E. Line Bearings

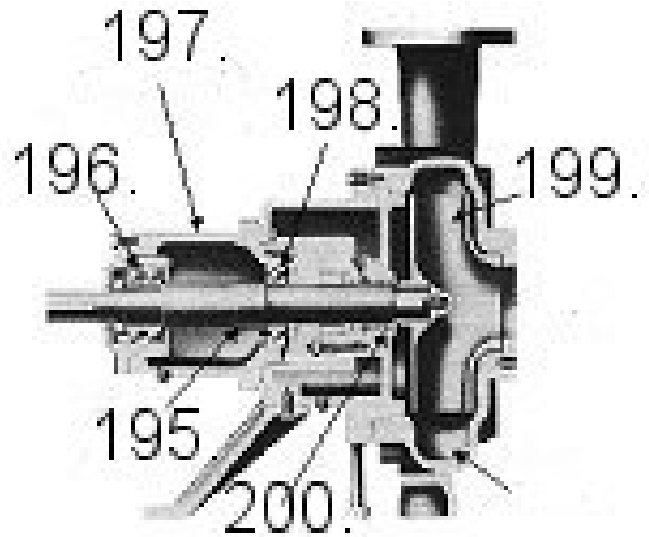

Please fax or e-mail the answer key to TLC
Western Campus Fax (928) 272-0747.

Special Notice to Help the Less Fortunate



Kavi and the believers in his church prayed fervently and lifted up praise to God before digging the well.

We here in the U.S. have it very good. Here is a story of and drilling a well just to have drinking water in India.

Kavi Viresh was accustomed to rejection. A Gospel for Asia missionary, Kavi knew he was laboring in hard soil in his village in Andhra Pradesh, India and the spiritual drought experienced by its people was worse than the physical drought they suffered in the summers. The people of this village lived hard lives focused on daily survival, and most did not have faith in any god.

By God's grace, Kavi has seen a church planted there—and believers who are eager to help him with outreach. Still, the hearts of many in the village have remained hard. Kavi has suffered beatings several times for sharing the Good News of Jesus. One time, a group of 30 people came to his house to attack him. The Gospel tracts he handed out were torn into pieces on many occasions.

"People told me, 'Your God is a great God.'"

But Kavi knew the people weren't really rejecting *him*—they were rejecting *Jesus* who sent him. And he knew there just had to be some way to get through to these people whom Jesus loved so much. That way turned out to be a Jesus Well. Before the Jesus Well was dug in this village, the people's only source of water was one government-built water tank that was not nearly enough to meet their basic needs. Kavi knew the Jesus Well would be a tangible way to show the villagers that Jesus loved them.

Sudhir Rao, a new Christian in the village, gladly provided his services as a mason to help with construction. The digging of the Jesus Well was in itself a miracle. Others had attempted to dig a well in the village but not seen water even at depths of 300 feet. So when Kavi saw water at around 100 feet, villagers were amazed.

"People told me, 'Your God is a great God,'" Kavi recalls. Even the village leader expressed heartfelt appreciation to Kavi for providing his people with water—and that he desired to see another well dug in a nearby area. Although the well was just dug in recent months, Kavi has already seen God wash away barriers in the villagers' hearts through its refreshing waters. Hearts have been brought that much closer to being able to receive the message of hope in Christ. And he has a vision of faith for how God will continue to work. "Through this Jesus Well, surely those who have beaten me and are against me will come to know the Lord Jesus," Kavi shared.

For more information, we welcome you to visit...

Gospel for Asia

Phone:

Toll Free: 800-946-2742
972-300-7777

Address:

Gospel for Asia
1800 Golden Trail Ct.
Carrollton, TX 75010
USA

Information:

info@gfa.org

Web Related questions:

webservant@gfa.org

[Gospel for Asia Web Site](#)

